

S-Series

High Performance, 2-stage, very high attenuation

12704 W. Arden Place
Butler, WI 53007 USA
Phone: 262-790-0092
Fax: 262-790-0095
Website: www.emissioncontrol.com
E-mail: info@emissioncontrol.com

Part Number System

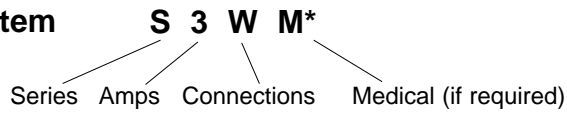

Agency Approvals:



Part Number	Current Rating Amps	Schematic
S3Q	2.5	<div style="display: flex; justify-content: space-between;"> LINE LOAD </div>
S3W	2.5	

Electrical Specs

Rated Voltage: 250VAC 50/60 Hz.
Rated Current: @ 40° C

Hipot Rating:
Line to Ground: 1800 VAC, 2 sec.
Line to Line: 1700 VDC, 2 sec.
Climatic Category: HPF (25/085/21)
Maximum leakage current:
each line to ground
@ 250 VAC 50 Hz .49ma

Minimum insertion loss — dB (50 ohm circuit)

Current Rating	Mode	Frequency - MHZ							
		.01	.05	.15	.5	1	5	10	30
3	Common	23	36	48	39	36	39	45	36
	Differential	--	14	32	49	56	64	64	59

* Low leakage medical versions
Available to meet UL544

Mechanical Specs

Construction: Metal case and cover. Internal components and terminations sealed with self-extinguishing resin.

Connections:

Q = Quick-Connects
.25"(6.3)x.03"(0.8)

W= Wire Leads
AWG 18

Dimensions: inches
(mm)

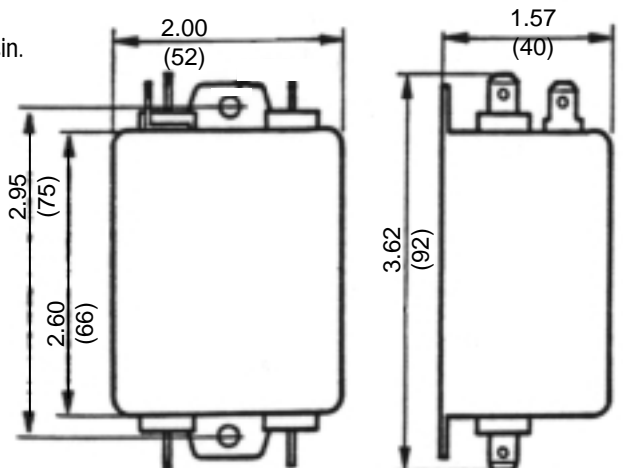
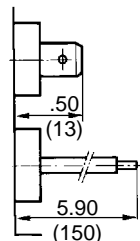

(2) Mounting Holes .20 DIA
(5.1)